

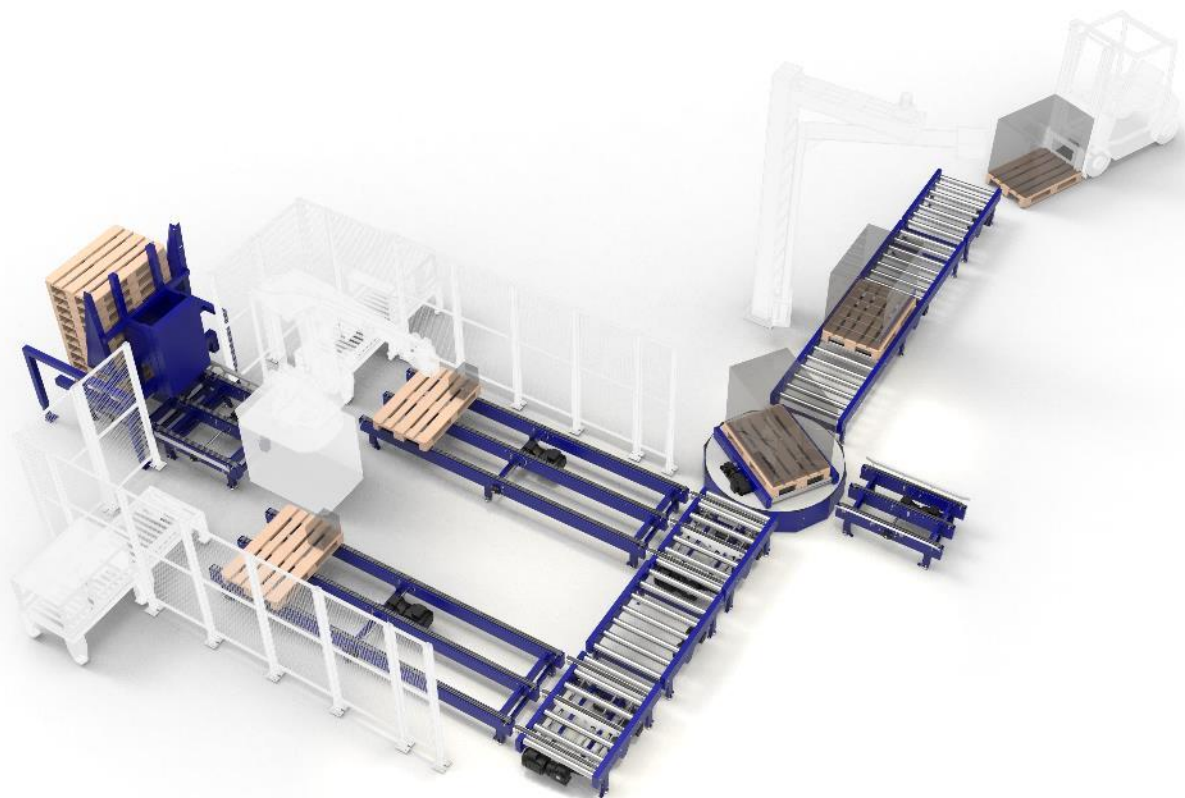

# PALLET CONVEYORS CATALOGUE

## COMPLETE PALLET TRANSPORT SOLUTION

- **Standard modules.** The modules are designed to be most cost effective at standard pallet sizes (EPAL). The standard conveyor modules are aimed at EUR pallets in sizes 800x1200mm and with a payload up to 1500kg.
- **Customization possibilities.** It is possible to order custom sizes of the modules to match various applications and usage purposes. All the products are designed to be modular, so later changes and extensions are easy to handle.
- **Space saving solution.** To reduce the overall size of conveyor modules, motors are located below or within conveyor frame. The standard conveyor solution, combining various modules, is installed at a height of 400 millimetres, making it very easy to insert and remove the pallets using a forklift truck.
- **Quick installation.** The modules are fully pre-assembled and tested to minimize installation time. All conveyors come with height adjustable floor mounts to make the installation process easy.
- **Easy maintenance.** All conveyor modules are easy to maintain. Drives chain tensioning and lubrication is easily accessible. All conveyors come with a maintenance schedule and spare part list.
- **Solution that lasts for years.** All our conveyors have a 2-year warranty. We never leave the customer alone with any concerns that may arise during use. After-sales support and upgrades are an integral part of our service.



## CONTROL SYSTEMS AND INTEGRATION

- **Control systems.** Our control system platform is prepared for controlling small and large size systems. Our project team is there for you deliver a solution that suits to your layout. We deliver the electrical control system, software, and HMIs for the complete turnkey solution.
- **Installation and commissioning services.** We manufacture and install control panels for your application needs. Our team is ready to help with installation and commissioning of the conveyor system at your factory or warehouse.

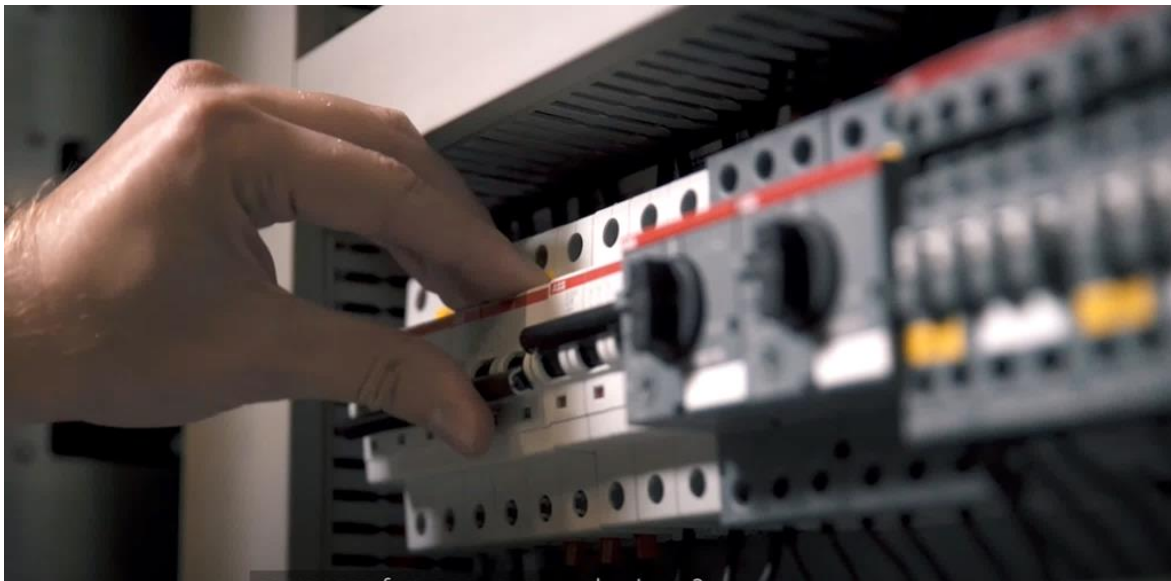

- **Integrations to external systems.** Conveyor system is often part of a manufacturing system and needs integrations to other systems or devices. Our control systems are prepared for with integration possibilities to other factory equipment and services.

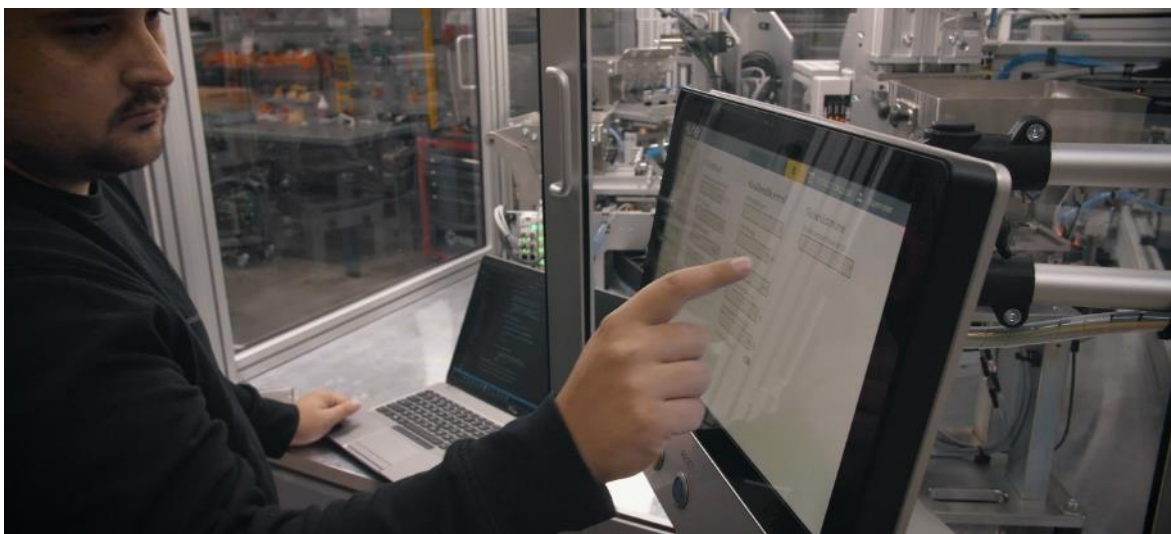

## OVERVIEW OF CONVEYOR PRODUCTS



**1. ROLLER CONVEYOR**  
p. 2



**2. CHAIN CONVEYOR**  
p. 4



**3. TRANSFER CONVEYOR**  
p. 6



**4. TURNTABLE CONVEYOR**  
p. 8

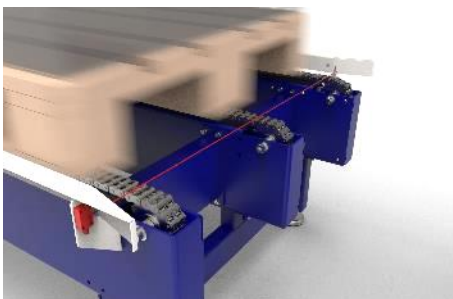

**5. CONVEYOR ACCESSORIES**  
p. 10

# 1. PALLET ROLLER CONVEYOR

## 1.1 Product description

- The roller conveyor is designed for straight line horizontal transport of industrial pallets. Conveyor can be ordered to suit EUR (EPAL) and other pallet sizes.
- Standard conveyor module has single motor and uses chain drive for all rollers.
- Conveyor module comes with adjustable feet (+/- 50mm) and floor mounts to compensate for irregularities of ground.
- Conveyor is designed for easy maintenance - tensioning of the roller chain is easily accessible.
- Accessories like sensors, pneumatic pushers, end stoppers are available.

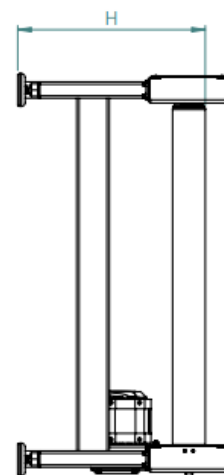
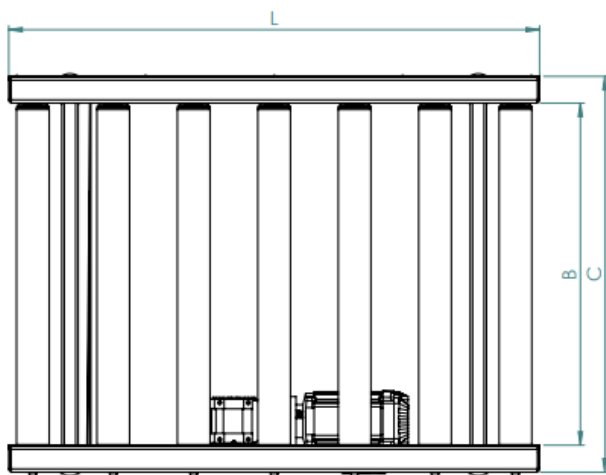

## 1.2 Dimensions

Conveying good width (A)	800 mm (custom width 400-1200 mm)
Conveying width (B)	840 mm
Conveyor width (C)	970 mm (A + 170 mm)
Conveying height (H)	400 mm (custom height 300-1200 mm)
Roller pitch (P)	197 mm
Conveyor length (L)	1300mm (custom length 750-6000 mm)

## 1.3 Technical data

<b>General data</b>	
Max. payload	Up to 1500kg
Conveyor speed	0.1 to 0.5 m/s (By default 0.5 m/s)
Direction	Both
Incline/decline	Normally horizontal use, incline/decline upon request.
<b>Drive</b>	
Motor	400V / 50Hz / 3 phase rated voltage
Power	0.12 to 0.75 kW
Roller chain	5/8" x 3/8"
<b>Roller</b>	
Dimesions	80x3 mm
Material	Steel, Zinc plated
<b>Frame</b>	
Material	Steel (Stainless Steel upon request)
Color	RAL 5022, other colors upon request.

## 2. PALLET CHAIN CONVEYOR

### 2.1 Product description

- The chain conveyor is designed for straight line horizontal transport industrial pallets. Conveyor can be ordered to suit EUR (EPAL) and other pallet sizes.
- A duplex precision roller chain with straight links is used on each chain run. Conveyor with 2 or 3 chain runs is available (3 chain runs recommended for pallets over 800kg).
- Conveyor is designed for easy maintenance - tensioning of the of the roller chain is easily accessible.
- Conveyor module comes with adjustable feet (+/- 50mm) and floor mounts to compensate for irregularities of ground.
- Accessories like sensors, pneumatic pushers, end stoppers are available.

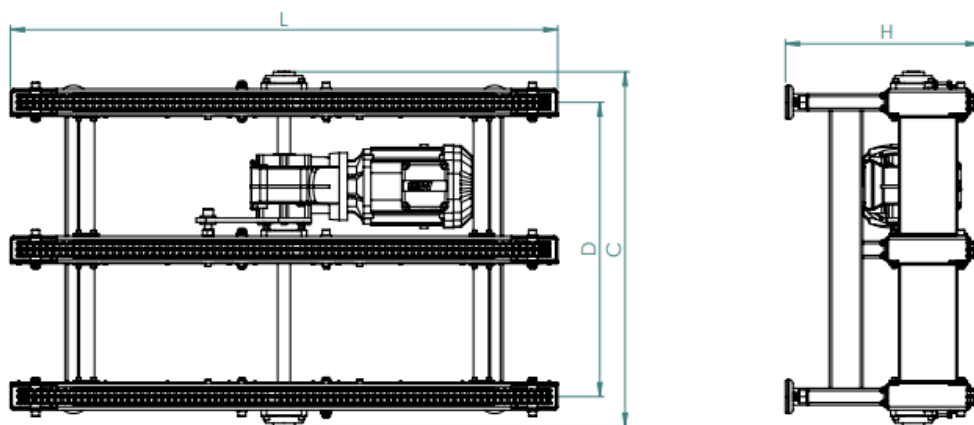
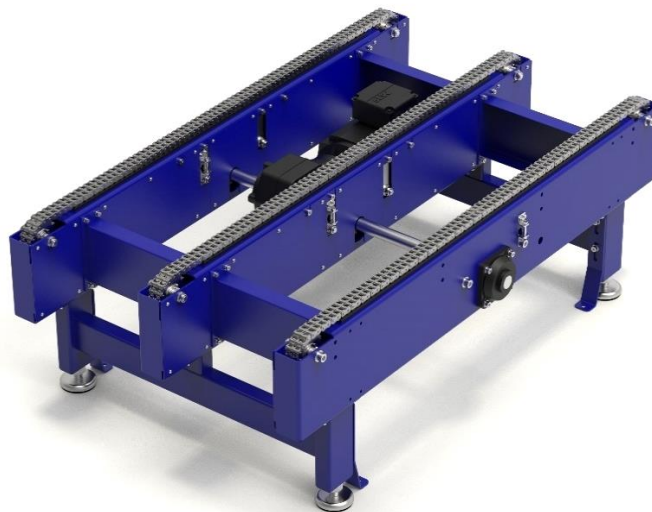

## 2.2 Dimensions

Dimensions	
Conveying good width (A)	800, 1000 mm (custom width 400-1200 mm)
Conveyor width (C)	845, 1045 mm (A+45)
Chain spacing (D)	700, 900 mm
Conveying height (H)	400 mm (custom height 300-1200 mm)
Conveyor length (L)	1300 mm (custom length 750-6000 mm)

## 2.3 Technical data

General data	
Max. payload	Up to 1500kg/m
Conveyor speed	0.1 to 0.5 m/s (By default 0.5 m/s)
Direction	Both
Incline/decline	Normally horizontal use, incline/decline upon request
Number of chains	2 or 3 (3 chains recommended for pallets over 800kg)
Drive	
Motor	400V / 50Hz / 3 phase rated voltage
Power	0.25 to 1.5 kW
Roller chain	5/8" x 3/8"
Frame	
Material	Steel (Stainless Steel upon request)
Color	RAL 5022, other colors upon request.



### 3. PALLET TRANSFER CONVEYOR

#### 3.1 Product description

- The pallet transfer conveyor is designed for 90° change of direction when transporting industrial pallets. Conveyor can be ordered to suit EUR (EPAL) and other industrial pallet sizes.
- The chain runs are lifted and lowered by electrically driven parallel mechanism.
- Chain conveyor uses duplex precision roller chain with straight links on both chain runs.
- All rollers are chain driven by single drive.
- Conveyor module comes with adjustable feet (+/- 50mm) and floor mounts to compensate for irregularities of ground.
- Accessories like sensors, pneumatic pushers, end stoppers are available.

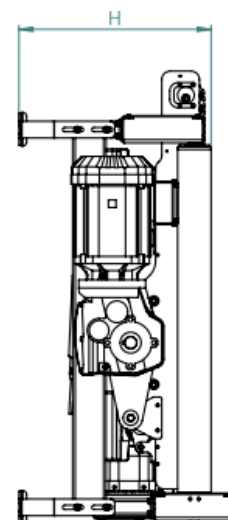
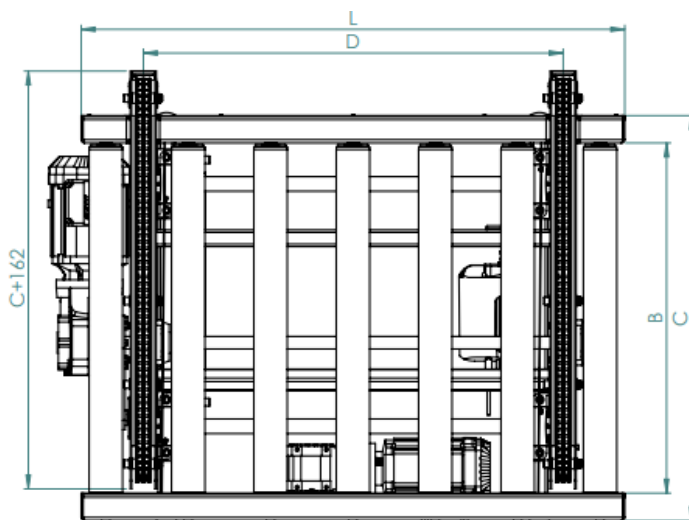

## 3.2 Dimensions

Dimensions	
Conveying good width (A)	800 mm (custom width 800-1200 mm)
Conveying width (B)	840 mm
Conveyor width (C)	970 mm (A + 170 mm)
Chain spacing (D)	1005 mm
Conveying height (H)	400 mm (custom height 350-1200 mm)
Roller pitch (P)	197 mm
Conveyor length (L)	1300 mm

## 3.3 Technical data

General data	
Max. payload	1500kg
Conveyor speed	0.1 to 0.5 m/s
Direction	Both
Incline/decline	Normally horizontal use, incline/decline upon request
Chain Conveyor	
Motor	400V / 50Hz / 3 phase rated voltage, IP55, CE
Power	0.12 to 0.75 kW
Roller chain	5/8" x 3/8"
Number of chains	2 or 3 (3 chains recommended for pallets over 800kg)
Lifting System	
Motor	24V, 10.3A
Power	250W
Stroke	30 mm
Roller Conveyor	
Motor	400V / 50Hz / 3 phase rated voltage, IP55, CE
Power	0.12 to 0.75 kW
Rollers	80x3mm, Steel, Zinc plated
Roller chain	5/8" x 3/8"
Frame	
Material	Steel or Stainless Steel
Color	RAL 5022, other colors upon request.

## 4. PALLET TURNTABLE CONVEYOR

### 4.1 Product description

- The turntable conveyor is designed for changing of direction of pallet or turning the pallet between 0° to 270° degrees.
- Conveyor can be ordered to suit EUR (EPAL) and other industrial pallet sizes.
- The turning motion is realized by electrical drive connected directly to the turntable assembly.
- Roller conveyor module has single motor and uses chain drive for all rollers.
- Conveyor module comes with adjustable feet (+/- 50mm) and floor mounts to compensate for irregularities of ground.
- The chain tensioning system is designed for easy re-tensioning of the precision roller chain.
- Accessories like sensors, pneumatic pushers, end stoppers are available.

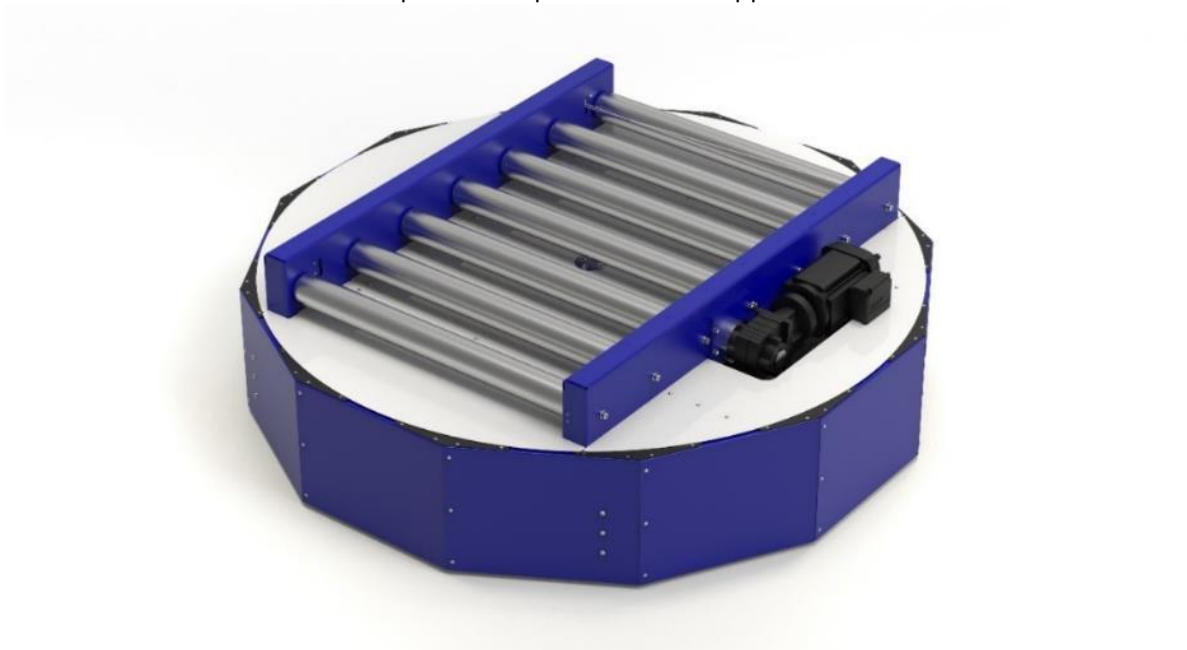

### 4.2 Dimensions

Conveying good width	800 mm
Conveying width (B)	840 mm
Conveyor length (L)	1300 mm
Conveying height (H)	400 mm (custom height 400-1200 mm)
Roller pitch (P)	197 mm

Module length (E)

1670 mm

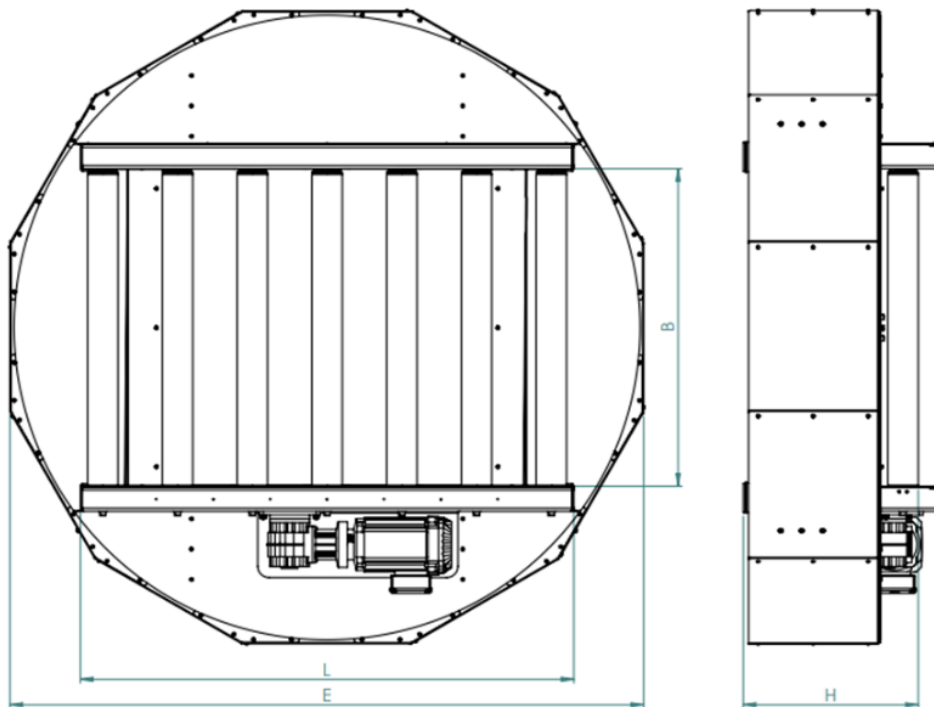

### 4.3 Technical data

<b>General data</b>	
Max. payload	1500kg
Conveyor speed	0.1 to 0.5 m/s
Turntable speed	90° in 4 s
Incline/decline	Horizontal only
<b>Roller Conveyor</b>	
Motor	400V / 50Hz / 3 phase rated voltage
Power	0.12 to 0.75 kW
Rollers	80x3 mm, Steel, Zinc plated
Roller chain	5/8" x 3/8"
<b>Turntable</b>	
Motor	400V / 50Hz / 3 phase rated voltage
Power	0.18 kW
<b>Frame</b>	
Material	Steel or Stainless Steel
Color	RAL ..., other colors upon request.

## 5. CONVEYOR ACCESSORIES

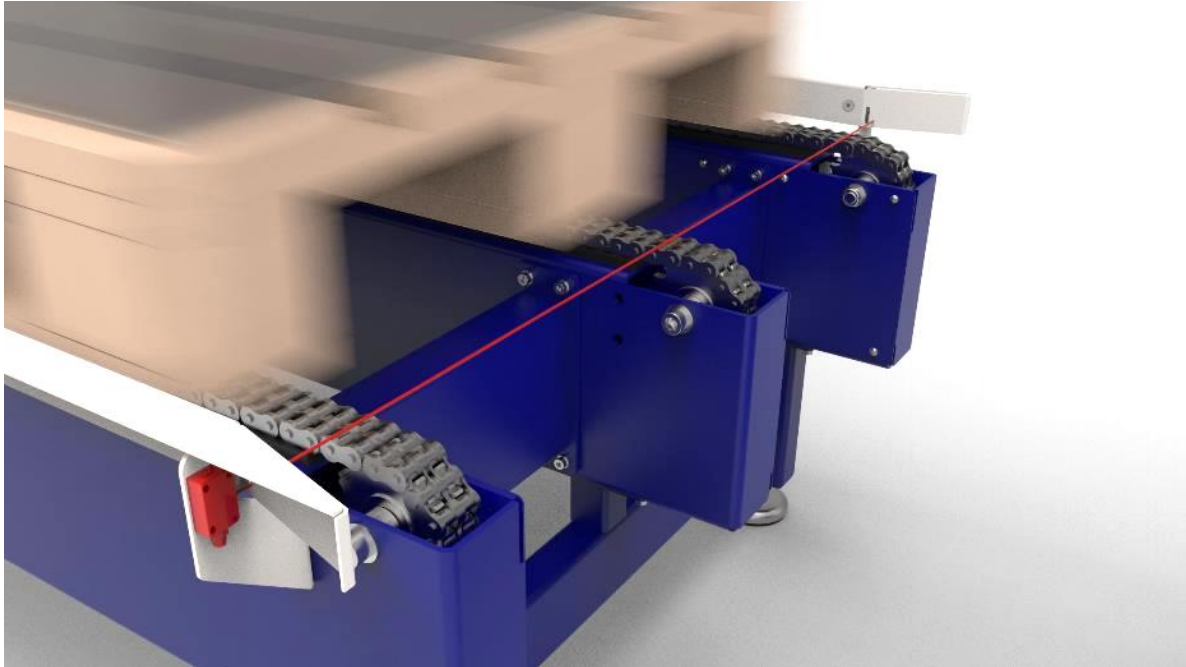

Conveyor accessories are available upon request.

<b>Sensor</b>	Photoelectric through-beam sensor. If the light beam between the two sensor devices is interrupted, the pallet is detected.
<b>End stop</b>	Metal barrier for stopping the pallet at a desired position
<b>Pneumatic stoppers</b>	Pneumatically operated barrier to stop pallet at desired position. Can be lifted and lowered pneumatically.
<b>Pneumatic pushers</b>	Pneumatically operated pusher to move pallet at desired position.
<b>Side guides</b>	Side guides for conveyor to position the pallet while moving
<b>Fork lift protection</b>	Protection of the conveyor to prevent collisions while working with forklifts.
<b>Pallet guides</b>	For positioning the pallet while placing it on the conveyor with robot or forklift.
<b>Positioning collars</b>	Collars for roller to guide the pallet on conveyor.

## ABOUT HOOB COMPANY

Hoob is a factory automation and machine building company. We design and manufacture automated solutions industrial applications. Our customers are manufacturing companies that need high-quality and efficient automation solutions. Our strategy is to provide turnkey factory automation solutions – design, manufacturing, installation, and after-sales support. Our product portfolio includes standardised solutions that are adapted to each customer’s specific requirements.

- **Contact us for a request**

- **Company name:** HOOB OÜ
- **Email:** [hoob@hoob.ee](mailto:hoob@hoob.ee)
- **Phone:**+3725012419
- **Mail/ visiting address:** Ringi tee 13-4, Jüri alevik, Rae vald, Harju maakond, 75301 Estonia
- **Registration number:** 127754785
- **VAT number:** EE101896126
- **Homepage:** [www.hoob.ee/en](http://www.hoob.ee/en)



**Copyright & intellectual property rights.** Text, images, graphics, and their arrangement, are protected by copyright and other protective legislation. Reproduction, modification, transfer or publication of any part or the entire content of this document in any form is prohibited. This document is intended exclusively for informational purposes and for intended use and does not authorize replication of the corresponding products.